

ZASTOSOWANIE

Wentylatory Q przeznaczone są do transportu czystego powietrza, mają wiele zastosowań w przemyśle, gdzie w procesach technologicznych należy dostarczyć powietrze o wysokim ciśnieniu m.in.:

- dostarczanie powietrza do układów palników gazowych,
- układy filtracyjne,
- transport pneumatyczny.

KONSTRUKCJA

- wysokociśnieniowy wentylator promieniowy o napędzie bezpośrednim,
- wirnik nitowany z blachy stalowej z łopatkami prostymi, wyważony dynamicznie wg ISO 1940-1,
- obudowa spawana z blachy stalowej, malowana proszkowo,
- wentylator malowany na kolor niebieski RAL 5010,
- maksymalna temperatura tłoczonego medium 80°C,
- temperatura otoczenia silnika od -20°C do +40°C,
- figura LG270.

SILNIK ELEKTRYCZNY

- asynchroniczny, trójfazowy, 230/400V, 50Hz (w zależności od mocy silnika),
- asynchroniczny, trójfazowy, 400/690V, 50Hz (w zależności od mocy silnika),
- klasa sprawności IE3,
- stopień ochrony IP54,
- klasa izolacji F,
- do regulacji częstotliwościowej (silniki trójfazowe).

WYKONANIA SPECJALNE

- dowolna figura LG/RD
- silnik na inne niż standardowe napięcie oraz częstotliwość zasilania.



WWW



CE

FIGURY

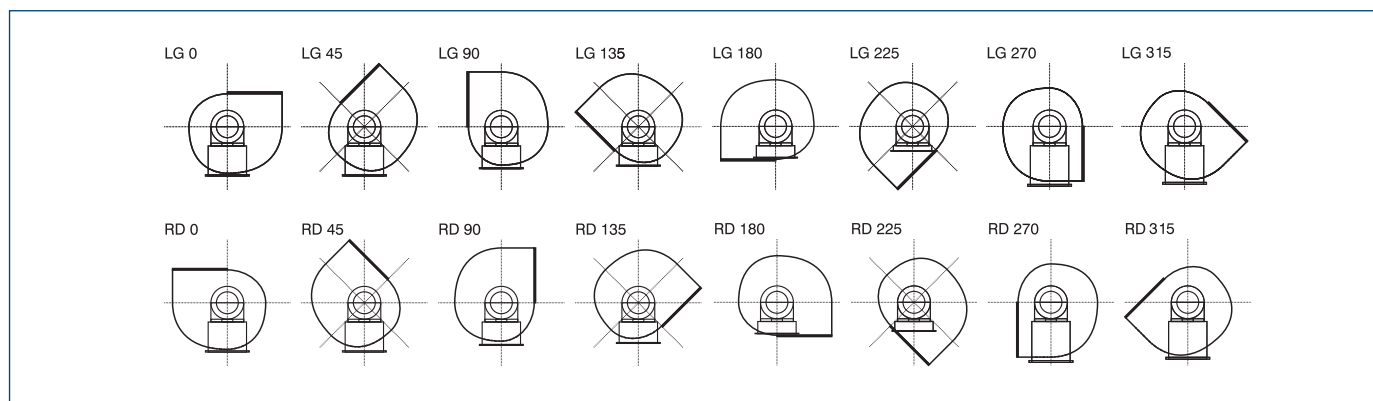

CHARAKTERYSTYKI PRACY

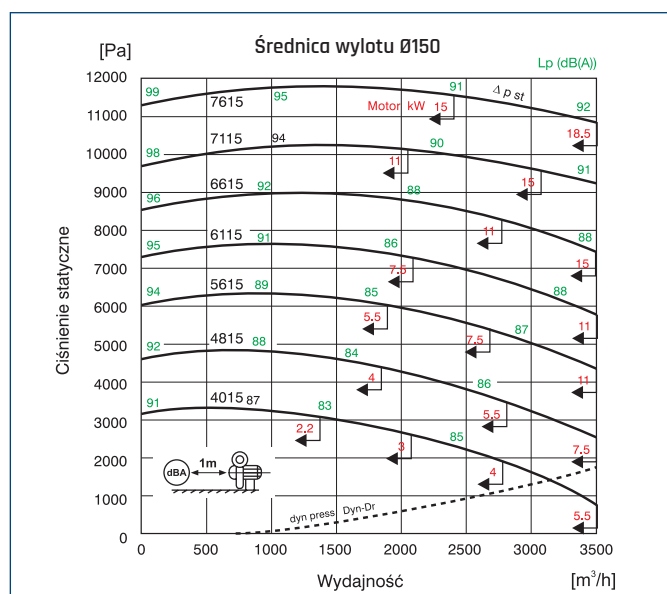
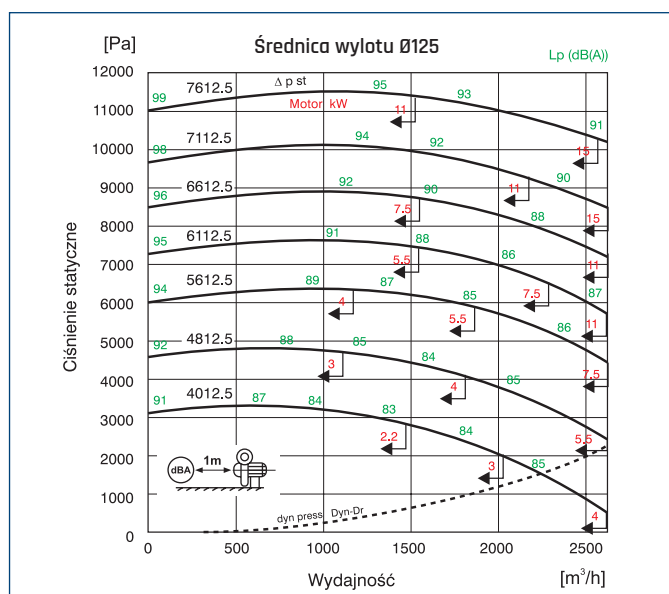
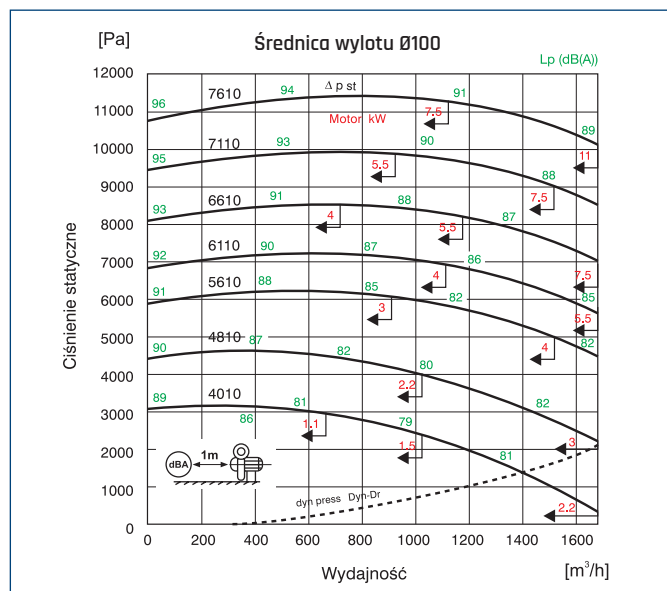
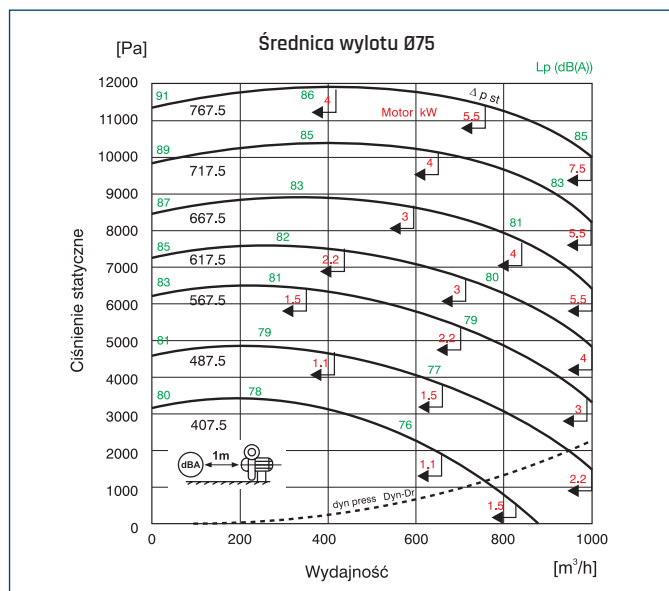
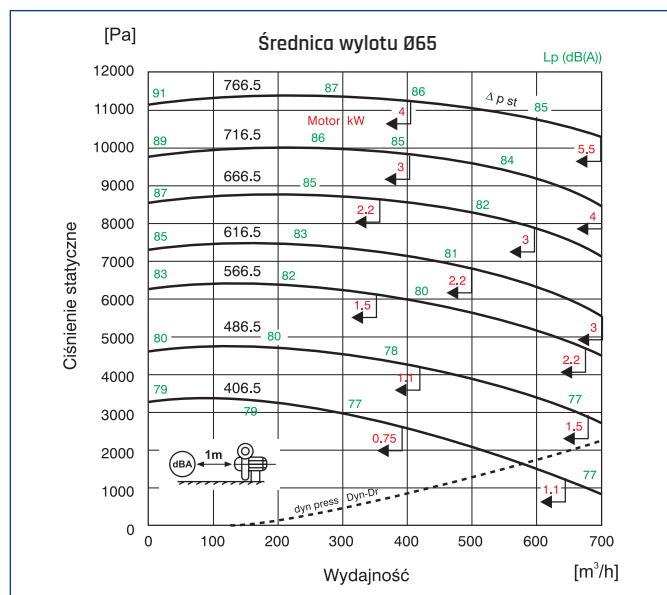
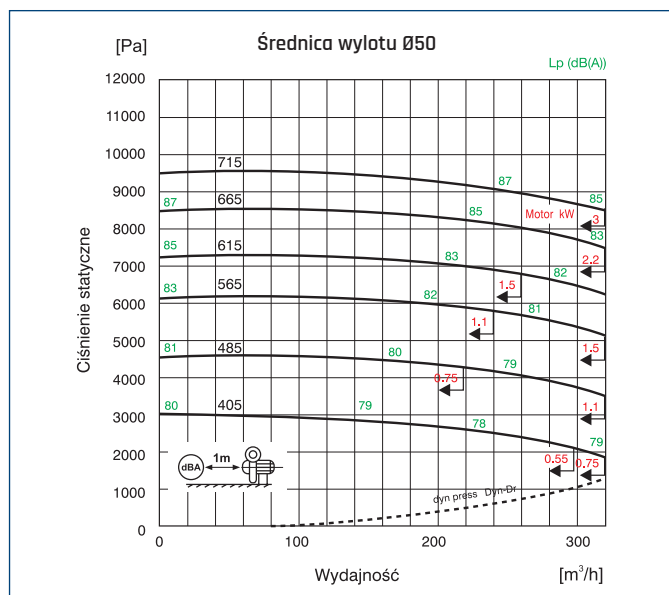

WYMIARY [mm]

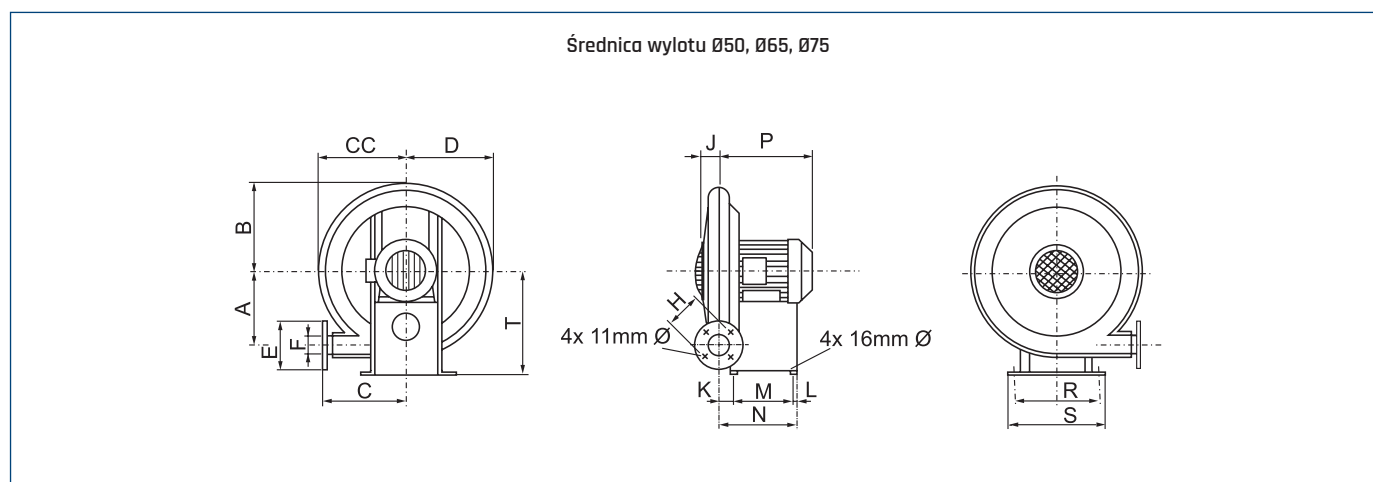

Typ	A	B	C	CC	D	E	F	H	J	K	L	silnik [kW]	M	N	P	R	S	T	masa [kg]
40 5						140	50	108				0,55	153	235	267	267	305	362	31
40 6,5	260	277	260	265	290	140	65	108	50	57	25	0,75/1,1	153	235	272	267	305	372	35
40 7,7						160	75	127				1,5	204	286	287	318	356	382	38
48 5						140	50	108				0,75/1,1	153	235	272	267	305	385	41
48 6,5	298	318	288	304	330	140	65	108	50	57	25	1,5	204	286	287	318	356	395	44
48 7,5						160	75	127				2,2	204	286	315	318	356	395	46
56 5						140	50	108				1,1	153	235	272	267	305	428	46
56 6,5	337	356	327	343	368	140	65	108	50	57	25	1,5	204	286	287	318	356	438	49
56 7,5						160	75	127				2,2	204	286	315	318	356	438	51
												3,0	204	286	344	318	356	443	59
												4,0	204	286	344	318	356	460	68
												5,5/7,5	241	324	432	368	406	468	81
61 5						140	50	108				1,5	204	286	287	318	356	457	54
61 6,5	362	381	352	368	394	140	65	108	50	57	25	2,2	204	286	315	318	356	457	56
61 7,5						160	75	127				3,0	204	286	344	318	356	467	64
												4,0	204	286	384	318	356	479	73
												5,5/7,5	241	324	432	368	406	479	81
66 5						140	50	108				1,5	204	286	287	318	356	480	59
66 6,5	387	406	377	393	419	140	65	108	50	57	25	2,2	204	286	315	318	356	480	61
66 7,5						160	75	127				3,0	204	286	344	318	356	490	70
												4,0	204	286	384	318	356	502	79
												5,5/7,5	241	324	432	368	406	480	92
71 5						140	50	108				3,0	204	286	344	318	356	499	80
71 6,5	413	432	403	419	445	140	65	108	50	57	25	4,0	204	286	384	318	356	511	89
71 7,5						160	75	127				5,5/7,5	241	324	432	368	406	499	102
76 6,5	439	439	457	429	470	140	65	108	50	57	25	4,0	204	286	384	318	356	525	99
76 7,5						160	75	127				5,5/7,5	241	324	432	368	406	525	112

WYMIARY [mm]

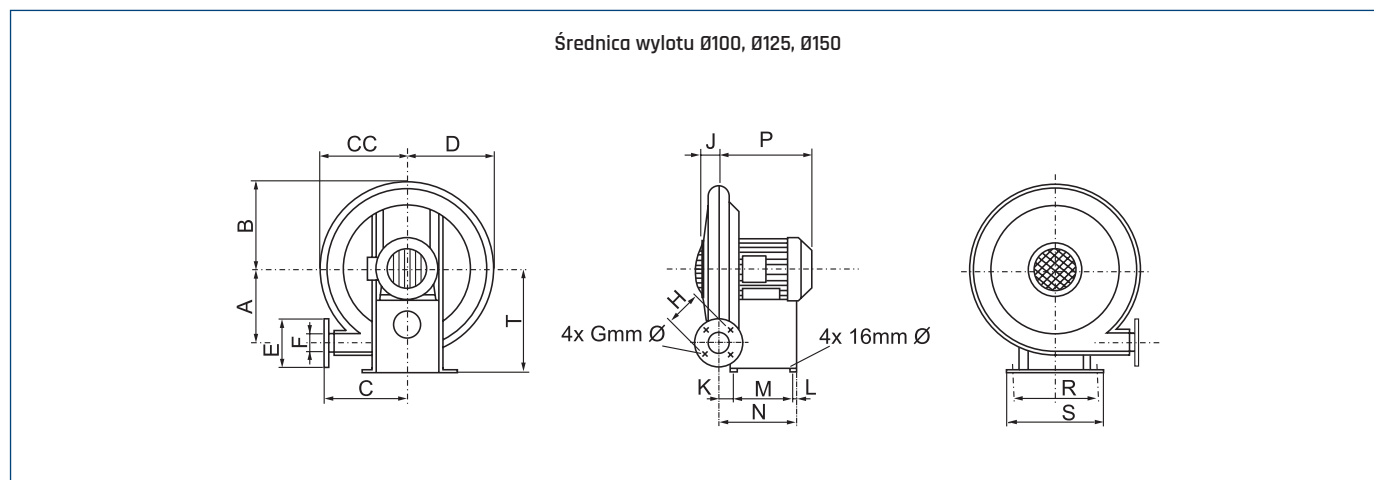

Typ	A	B	C	CC	D	E	F	G	H	J	K	L	silnik [kW]	M	N	P	R	S	T	masa [kg]	
40 10	275	295	260	274	315	197	100	11	152	50	75	25	1,1	153	235	290	267	305	400	38	
													1,5	203	303	317	318	356	410	41	
													2,2	203	303	330	318	356	410	43	
48 10	314	334	297	313	355	197	100	11	152	50	75	25	1,5	203	303	317	318	356	438	48	
													2,2	203	303	330	318	356	438	50	
													3,0	203	303	360	318	356	448	58	
													4,0	203	303	360	318	356	460	67	
													5,5/7,5	241	341	430	368	406	438	80	
56 10	352	372	335	351	393	197	100	11	152	50	75	25	3,0	203	303	360	318	356	467	65	
													4,0	203	303	380	318	356	479	74	
													5,5/7,5	241	341	430	368	406	480	87	
61 10	378	397	360	376	418	197	100	11	152	50	75	25	3,0	203	303	360	318	356	490	73	
													4,0	203	303	380	318	356	490	82	
													5,5/7,5	241	341	430	368	406	499	95	
66 10	403	422	386	401	443	197	100	11	152	50	75	25	4,0	203	303	380	318	356	525	92	
													5,5/7,5	241	341	430	368	406	525	105	
71 10	429	447	410	426	469	197	100	11	152	50	75	25	5,5/7,5	241	341	430	368	406	550	116	
													11	343	443	563	432	470	550	158	
76 10	454	472	436	451	494	197	100	11	152	50	75	25	7,5	241	341	430	368	406	570	127	
													11	343	443	563	432	470	570	169	
40 12,5 40 15	286	305	280	280	330	232	125	11	191	60	111	32	2,2	181	315	342	311	356	435	51	
						255	150	11	216	60	111	32	3,0	181	315	372	311	356	435	60	
														4,0	181	315	393	311	356	435	69
														5,5/7,5	200	353	441	362	406	435	82
48 12,5 48 15	324	343	305	318	368	232	125	11	191	60	111	32	3,0	181	315	372	311	356	464	71	
						255	150	11	216	60	111	32	4,0	181	315	393	311	356	464	80	
														5,5/7,5	200	353	441	362	406	464	93
56 12,5 56 15	362	381	339	355	406	232	125	11	191	60	111	32	4,0	181	315	393	311	356	502	91	
						255	150	11	216	60	111	32	5,5/7,5	200	353	441	362	406	502	104	
														11/15	251	455	572	425	470	502	146
61 12,5 61 15	387	406	375	381	432	232	125	11	191	60	111	32	5,5/7,5	200	353	441	362	406	527	111	
						255	150	11	216	60	111	32	11/15	251	455	572	425	470	527	153	
66 12,5 66 15	413	432	390	406	457	232	125	11	191	60	111	32	5,5/7,5	200	353	441	362	406	552	122	
						255	150	11	216	60	111	32	11/15	251	455	572	425	470	552	164	
71 12,5 71 15	438	457	416	432	482	232	125	11	191	60	111	32	7,5	200	353	441	362	406	578	133	
						255	150	11	216	60	111	32	11/15	251	455	572	425	470	578	175	
														18,5	271	495	614	425	470	578	194
76 12,5 76 15	464	464	430	457	508	232	125	11	191	60	111	32	11/15	251	455	572	425	470	603	187	
						255	150	11	216	60	111	32	18,5	271	495	614	425	470	603	206	
														22,0	271	495	630	489	534	603	233